

RACAL INSTRUMENTS

1260-167

RF MUX PLUG-IN

PUBLICATION NO. 980824-167

EADS North America Defense Test and Services, Inc.
4 Goodyear, Irvine, CA 92618
Tel: (800) 722-2528, (949) 859-8999; Fax: (949) 859-7139

info@eads-nadefense.com
sales@eads-nadefense.com
helpdesk@eads-nadefense.com
<http://www.eads-nadefense.com>



PUBLICATION DATE: January 09, 2001

Copyright 2000 by EADS North America Defense Test and Services, Inc. Printed in the United States of America. All rights reserved. This book or parts thereof may not be reproduced in any form without written permission of the publisher.

**THANK YOU FOR PURCHASING THIS
EADS NORTH AMERICA DEFENSE TEST AND SERVICES PRODUCT**

For this product, or any other EADS North America Defense Test and Services, Inc. product that incorporates software drivers, you may access our web site to verify and/or download the latest driver versions. The web address for driver downloads is:

<http://www.eads-nadefense.com/downloads>

If you have any questions about software driver downloads or our privacy policy, please contact us at:

info@eads-nadefense.com

WARRANTY STATEMENT

All EADS North America Defense Test and Services, Inc. products are designed and manufactured to exacting standards and in full conformance to EADS ISO 9001:2000 processes.

This warranty does not apply to defects resulting from any modification(s) of any product or part without EADS North America Defense Test and Services, Inc. express written consent, or misuse of any product or part. The warranty also does not apply to fuses, software, non-rechargeable batteries, damage from battery leakage, or problems arising from normal wear, such as mechanical relay life, or failure to follow instructions.

This warranty is in lieu of all other warranties, expressed or implied, including any implied warranty of merchantability or fitness for a particular use. The remedies provided herein are buyer's sole and exclusive remedies.

For the specific terms of your standard warranty, or optional extended warranty or service agreement, contact your EADS North America Defense Test and Services, Inc. customer service advisor. Please have the following information available to facilitate service.

1. Product serial number
2. Product model number
3. Your company and contact information

You may contact your customer service advisor by:

E-Mail:	Helpdesk@eads-nadefense.com	
Telephone:	+1 800 722 3262	(USA)
Fax:	+1 949 859 7309	(USA)

RETURN of PRODUCT

Authorization is required from EADS North America Defense Test and Services, Inc. before you send us your product for service or calibration. Call or contact the Customer Support Department at 1-800-722-3262 or 1-949-859-8999 or via fax at 1-949-859-7139. We can be reached at: helpdesk@eads-nadefense.com.

PROPRIETARY NOTICE

This document and the technical data herein disclosed, are proprietary to EADS North America Defense Test and Services, Inc., and shall not, without express written permission of EADS North America Defense Test and Services, Inc., be used, in whole or in part to solicit quotations from a competitive source or used for manufacture by anyone other than EADS North America Defense Test and Services, Inc. The information herein has been developed at private expense, and may only be used for operation and maintenance reference purposes or for purposes of engineering evaluation and incorporation into technical specifications and other documents which specify procurement of products from EADS North America Defense Test and Services, Inc.

DISCLAIMER

Buyer acknowledges and agrees that it is responsible for the operation of the goods purchased and should ensure that they are used properly and in accordance with this handbook and any other instructions provided by Seller. EADS North America Defense Test and Services, Inc. products are not specifically designed, manufactured or intended to be used as parts, assemblies or components in planning, construction, maintenance or operation of a nuclear facility, or in life support or safety critical applications in which the failure of the EADS North America Defense Test and Services, Inc. product could create a situation where personal injury or death could occur. Should Buyer purchase EADS North America Defense Test and Services, Inc. product for such unintended application, Buyer shall indemnify and hold EADS North America Defense Test and Services, Inc., its officers, employees, subsidiaries, affiliates and distributors harmless against all claims arising out of a claim for personal injury or death associated with such unintended use.

FOR YOUR SAFETY

Before undertaking any troubleshooting, maintenance or exploratory procedure, read carefully the **WARNINGS** and **CAUTION** notices.



CAUTION
RISK OF ELECTRICAL SHOCK
DO NOT OPEN



This equipment contains voltage hazardous to human life and safety, and is capable of inflicting personal injury.



If this instrument is to be powered from the AC line (mains) through an autotransformer, ensure the common connector is connected to the neutral (earth pole) of the power supply.



Before operating the unit, ensure the conductor (green wire) is connected to the ground (earth) conductor of the power outlet. Do not use a two-conductor extension cord or a three-prong/two-prong adapter. This will defeat the protective feature of the third conductor in the power cord.



Maintenance and calibration procedures sometimes call for operation of the unit with power applied and protective covers removed. Read the procedures and heed warnings to avoid “live” circuit points.

Before operating this instrument:

1. Ensure the proper fuse is in place for the power source to operate.
2. Ensure all other devices connected to or in proximity to this instrument are properly grounded or connected to the protective third-wire earth ground.

If the instrument:

- fails to operate satisfactorily
- shows visible damage
- has been stored under unfavorable conditions
- has sustained stress

Do not operate until, performance is checked by qualified personnel.

Racal Instruments

EC Declaration of Conformity

We

Racal Instruments Inc.
4 Goodyear Street
Irvine, CA 92718

declare under sole responsibility that the

1260-167A Single 1x6 RF Mux Module P/N 407773-001
1260-167B Dual 1x6 RF Mux Module P/N 407773-002

conforms to the following Product Specifications:

Safety: EN 61010-1

EMC: Immunity: EN61326, Class A, Table 1
Emissions: EN61326, Class A, Table 3

Supplementary Information:

The above specifications are met when the product is installed in a Racal Instruments certified enclosure, with faceplates installed over all unused slots, as applicable.

The product herewith complies with the requirements of EN61010-1 and EN61326.

Irvine, CA, February 22, 2001

Quality Manager

This page was left intentionally blank.

Table of Contents

Chapter 1	1-1
SPECIFICATIONS	1-1
Introduction – 1260-167A/B	1-1
Power Dissipation – 1260-167A/B	1-3
Ordering Information	1-4
Chapter 2	2-1
INSTALLATION INSTRUCTIONS	2-1
Unpacking and Inspection	2-1
Reshipment Instructions	2-1
Installation	2-1
Module Configuration	2-2
Front Panel Connectors 1260-167A	2-2
Front Panel Connectors 1260-167B	2-4
Mating Connectors	2-6
Chapter 3	3-1
MODULE OPERATION	3-1
Reply to the MOD:LIST? Command	3-1
Operating in Register-Based Mode	3-2
1260-167 Example Code	3-6

Chapter 4.....4-1

PRODUCT SUPPORT.....4-1

 Product Support4-1

 Warranty.....4-1

List of Figures

Figure 1-1, 1260-167B1-1

Figure 2-1, 1260-167A SMA Connector Designations2-2

Figure 2-2, 1260-167A Relay Diagram2-2

Figure 2-3, 1260-167A Block Diagram.....2-3

Figure 2-4, 1260-167A SMA Connector Designations2-4

Figure 2-5, 1260-167B SMA Connector Designations2-5

Figure 2-6, 1260-167B Block Diagram.....2-5

List of Tables

Table 3-1, Register Offset Addresses of the 1260-167 Module3-3

Table 3-2, ID Register Functionality of the 1260-1673-3

Table 3-3, Port A Register Functionality of the 1260-167 Module3-4

Table 3-4, Port B Register Functionality of the 1260-167 Module3-4

Table 3-5, EPROM Descriptor Functionality of the 1260-167 Module3-5

This page was left intentionally blank.

Chapter 1

SPECIFICATIONS

Introduction – 1260-167A/B

The 1260-167A and 1260-167B are RF plug-in switch modules developed for a variety of platforms such as the 1260-100 Adapt-a-Switch Carrier and the 1256 Switching System. These switches are software-configurable single (-167A) and dual 1X6 (-167B) RF multiplexers for DC to 18GHz.

The 1260-167 modules include the following features:

- Standard Adapt-a-Switch™ and 1256 Switching System plug-in design, providing for ease of replacement.
- Data-Driven embedded descriptor, allowing immediate use with any platform compatible with the Adapt-a-Switch standard, regardless of firmware level.



Figure 1-1, 1260-167B

Specifications – 1260-167A/B

Input / Output Specifications				
Frequency Range (GHz)	DC-3	3-8	8-12.4	12.4-18
VSWR (Max dB)	1.15:1	1.25:1	1.35:1	1.45:1
Insertion loss (Max dB)	0.15	0.25	0.24	0.45
Isolation (Max dB)	85	75	65	65
RF Input Power				
Frequency Range (GHz)	DC-0.1	0.1-1	1.10	10.18
Max Input Power (Watts)	490	180	60	50
Relay Operate Time	15m sec typical			
Switch Contact Lifetime	1 Million cycles per position			
Available I/O Channels	Single 1x6 RF Mux			
Shock	30g, 11 ms, ½ sine wave			
Vibration	0.013 in. P-P, 5-55 Hz			
Bench Handling	4 in., 45°			
Cooling	See 1260-100 cooling data			
Temperature				
Operating	-20°C to +60°C			
Non-operating	-40°C to +75°C			
Relative Humidity	95 +/-5% RH non condensing; 75+/-5 %RH above 30°C; 45+/-5 %RH above 40°C			
Altitude				
Operating	10,000 feet			
Non-operating	15,000 feet			
Power Requirements +5 VDC Amps Maximum	1260-167A	1260-167B		
	1.15A	2.15A		

Weight	1260-167A	1260-167B
	6.9 oz (1.95Kg)	9.8 oz (2,78Kg)
Mean Time Between Failures (MTBF)	1260-167A	869,262 Hours
	1260-167B	563,629 Hours
	Calculated per MIL-HBK-217, ground-benign, 30°C, as design goal (RF relay MTBF 1,000,000 operations per switch at rated load)	
Mean Time to Repair (MTTR)	< 5 minutes	

Power Dissipation – 1260-167A/B

The cooling of the Adapt-a-Switch carrier is dependent upon the chassis into which it is installed. The carrier can nominally dissipate approximately 100W. Even with all channels driven to maximum outputs, up to two 1260-167A plug-ins may be used together in a 1260-100 without exceeding the maximum allowable power dissipation of the carrier.

If the 1260-167A will be used in conjunction with other cards, the dissipation should be computed and summed with the total worst-case dissipation of the remaining modules.

For example, a 1260-167A module would dissipate the following energy:

Quiescent power dissipation = 0.75W maximum

With one coil energized = 5.75 W maximum

For example, a 1260-167B module would dissipate the following energy:

Quiescent power dissipation = 0.75W maximum

With one coil energized = 5.75 W maximum

With two coils energized = 10.75 W maximum

This is acceptable power dissipation for an individual plug-in module. If one additional module is likewise loaded, then the overall carrier dissipation is approximately 11.5W for the –167A and 21.5W for the –167B, both of which are well within the cooling available in most commercial VXIbus chassis.

Ordering Information

Listed below are part numbers for both the 1260-167 switch module and available mating connector accessories. Each 1260-167 uses a single mating connector.

ITEM	DESCRIPTION	PART #
1260-167A RF Mux Module	Switch Module, 1x6 DC-18 GHz Consists of: P/N 405168-001 PCB Assy P/N 980824-167 Manual	407773-001
1260-167B RF Mux Module	Switch Module, 2 (1x6) DC-18 GHz Consists of: P/N 405168-002 PCB Assy P/N 980824-167 Manual	407773-002
Additional Manual		980824-167

INSTALLATION INSTRUCTIONS

Unpacking and Inspection



1. Remove the 1260-67 module and inspect it for damage. If any damage is apparent, inform the carrier immediately. Retain shipping carton and packing material for the carrier's inspection.
2. Verify that the pieces in the package you received contain the correct 1260-67 module option and the 1260-67 Users Manual. Notify EADS North America Defense Test and Services, Inc. if the module appears damaged in any way. Do not attempt to install a damaged module into a VXI chassis.
3. The 1260-67 module is shipped in an anti-static bag to prevent electrostatic damage to the module. Do not remove the module from the anti-static bag unless it is in a static-controlled area.

Reshipment Instructions

1. Use the original packing when returning the switching module to EADS North America Defense Test and Services, Inc. for calibration or servicing. The original shipping carton and the instrument's plastic foam will provide the necessary support for safe reshipment.
2. If the original packing material is unavailable, wrap the switching module in an ESD Shielding bag and use plastic spray foam to surround and protect the instrument.
3. Reship in either the original or a new shipping carton.

Installation

For instructions on installing the 1260-167 into a switching platform, refer to the user manual for that platform, in the "Getting Started" chapter under the "Inserting and Removing Plug-ins" section. Manuals are available at the Racal Instruments' web site: <http://www.racalinstruments.com>.

Module Configuration

The 1260-167 modules are software-selectable multiplexer plug-ins for switching platforms such as Adapt-a-Switch and 1256 System. The 1260-167A is a single 1X6 RF multiplexer, and the 1260-167B is a dual 1X6 RF multiplexer.

Front Panel Connectors 1260-167A

The 1260-167A has one front panel RF relay, labeled SW1, with 7 SMA connectors. See **Figure 2-1** for SMA connector designations. See **Figure 2-2** for the relay diagram, and **Figure 2-3** for a block diagram of the 1260-167A.

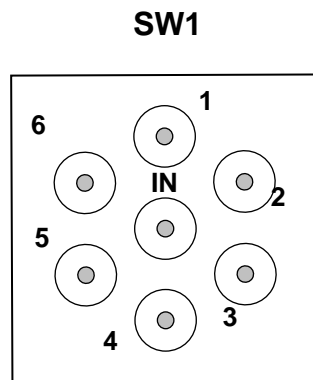

Figure 2-1, 1260-167A SMA Connector Designations

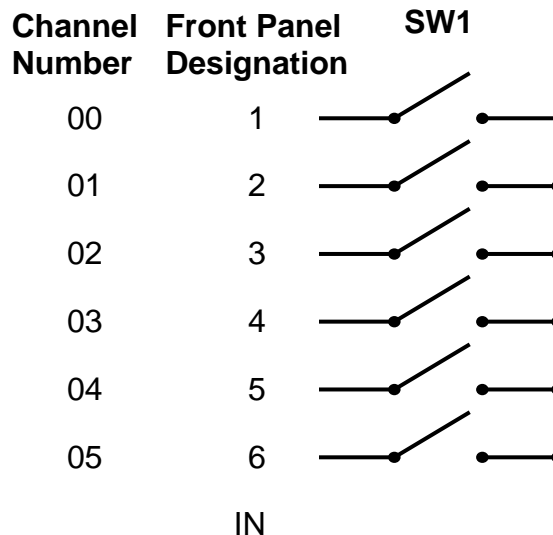

Figure 2-2, 1260-167A Relay Diagram

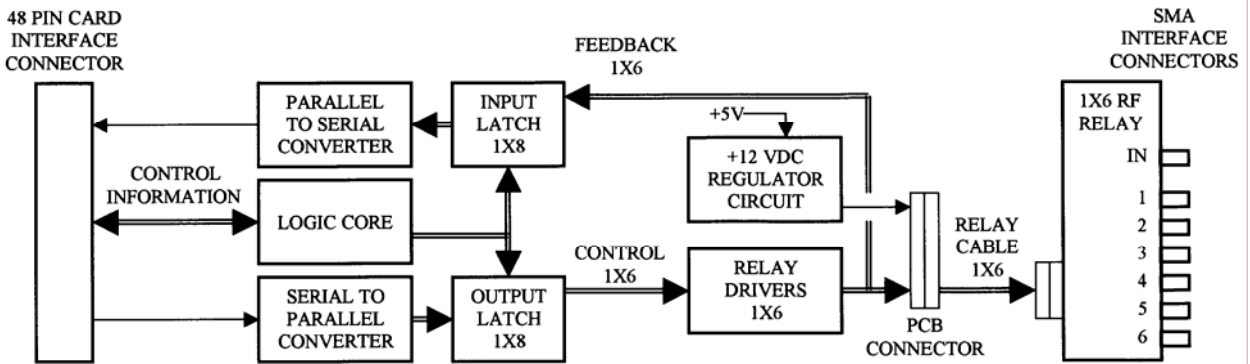

Figure 2-3, 1260-167A Block Diagram

Front Panel Connectors 1260- 167B

The 1260-167B has two front panel RF relays, labeled SW1 and SW2, with 7 SMA connectors each. See **Figure 2-4** for SMA connector designations. See **Figure 2-5** for the relay diagram and **Figure 2-6** for a block diagram of the 1260-167B.

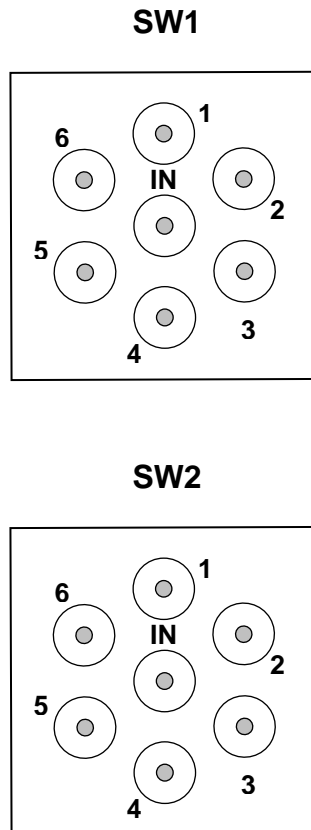

Figure 2-4, 1260-167A SMA Connector Designations

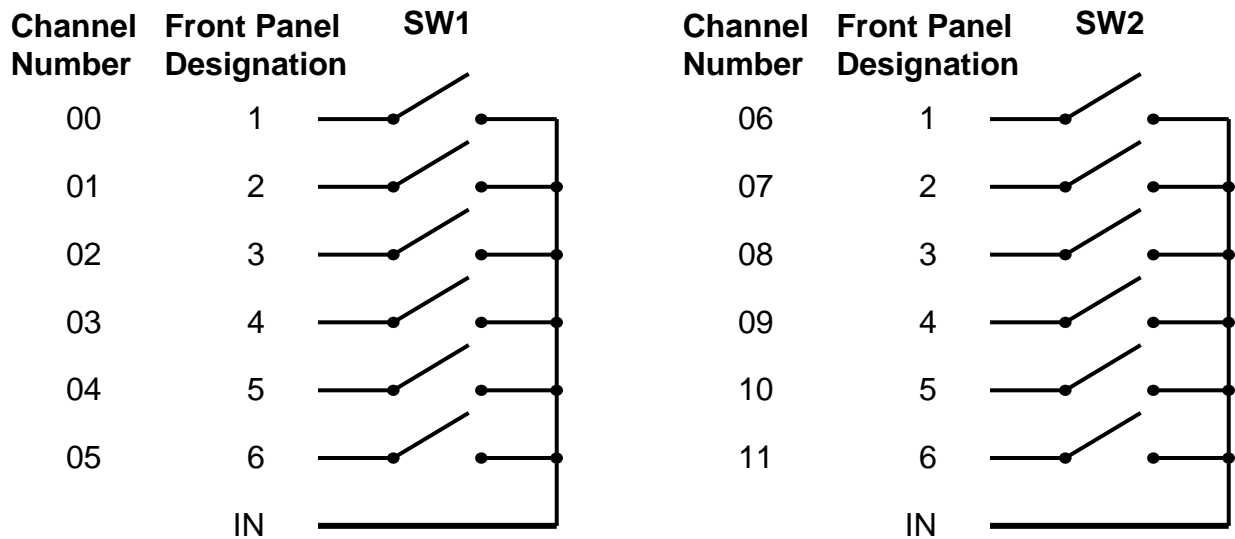

Figure 2-5, 1260-167B SMA Connector Designations

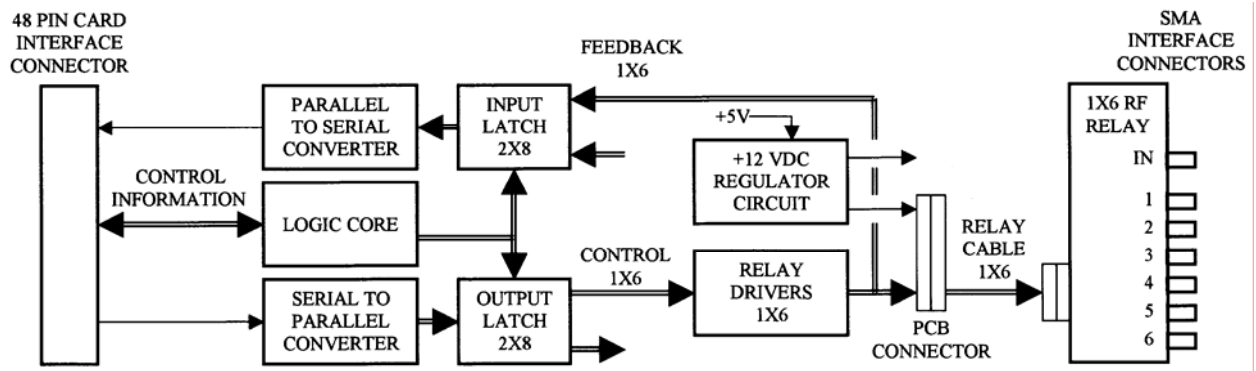

Figure 2-6, 1260-167B Block Diagram

Mating Connectors

Mating connectors are SMA type. Use connectors that are suitable for the type of connecting coax and frequency range to be used.

Chapter 3

MODULE OPERATION

Reply to the MOD:LIST? Command

The platform containing the 1260-167 returns a reply to the MOD:LIST? command. This reply is unique for each different 1260 series switch module. The syntax for the reply is:

<module address> : <module-specific identification string>

The value of <module-specific identification string> for the 1260-167 depends on the version (1260-167A or 1260-167B). For the single 1x6 switch (1260-167A), the string value is:

1260-167A SINGLE 1x6 RF SWITCHING MODULE

For the two 1x6 switch (1260-167B), the string value is:

1260-167B DUAL 1x6 RF SWITCHING MODULE

Thus, for a 1260-167A whose module address is 2, the reply to this query would be:

2 : 1260-167A SINGLE 1x6 RF SWITCHING MODULE

Operating in Register-Based Mode

The 1260-167 offers register-based mode when installed in VXI platforms that support it. In register-based mode, the 1260-167 is operated by directly writing and reading to/from ports controlling eight relays each. To access the various registers the following details must be assembled to generate an absolute address that can be wrote or read from:

The port and control registers are located in the VXIbus A24 Address Space. The A24 address for a port or control register depends on:

1. The A24 Address Offset assigned to the 1260-01T module by the Resource Manager program. The Resource Manager program is provided by the VXIbus slot-0 controller vendor. The A24 Address Offset is placed into the "Offset Register" of the 1260-01T by the Resource Manager.
2. The <module address> of the 1260-167 module. This is a value in the range from 1 and 12 inclusive.
3. The 1260-167 port or control register to be written to or read from. Each register on the 1260-167 has a unique offset from the base address.

The base A24 address for the 1260-167 module may be calculated by:

$$(A24 \text{ Offset of the } 1260-01T) + (1024 \times \text{Module Address of } 1260-167).$$

The A24 address offset is usually expressed in hexadecimal. A typical value of 204000_{16} is used in the examples that follow.

A 1260-167 with a module address of 7 would have the base A24 address computed as follows:

$$\begin{aligned} \text{Base A24 Address of } 1260-167 &= 204000_{16} + (400_{16} \times 7_{10}) \\ &= 205C00_{16} \end{aligned}$$

The port and control registers for Adapt-a-Switch plug-ins and conventional 1260-Series modules are always on odd-numbered A24 addresses. For port registers, the 1260-167 reads and writes to the same location. For control registers, the 1260-167 writes to one location, but reads back from another. **Table 3-1 and 3-5** provides offsets relative to the base address of the module for all port and control registers of the 1260-167. To obtain the absolute address where data is to be written or read from, the base address is added to the offset:

$$(\text{Base A24 } 1260-167 \text{ Address}) + \text{offset} = \text{absolute address}$$

So, for our example base A24 address computed earlier, the following absolute addresses would apply for the operations indicated:

- 205C01 Port A read or written at this location
- 205E01 ID register read at this location

Before explaining the particulars of reading and writing to port and control registers, it is necessary to understand how the registers interact with the 1260-167 relays. **Table 3-1 through 3-5** provide a detailed explanation of each register and how it interacts with the 1260-167 module.

Table 3-1, Register Offset Addresses of the 1260-167 Module

Register Name	Register Offsets to Add to Base Module Address	
	Write Location (hexadecimal)	Read Location (hexadecimal)
Port A	0x01	0x01
Port B	0x03	0x03
ID	Read Only	0x201
EPROM Descriptor	Read Only	0x203

Table 3-2, ID Register Functionality of the 1260-167

Register Table		ID Register
Module Version	Bit	Functionality Description
All	0	Always Reads 0x00 (Read Only)
	1	
	2	
	3	
	4	
	5	
	6	
	7	

Table 3-3, Port A Register Functionality of the 1260-167 Module

Register Table		Port A
Module Version	Bit	Functionality Description
All	0	Relay SW1-1 (0: switch open 1: switch closed)
	1	Relay SW1-2 (0: switch open 1: switch closed)
	2	Relay SW1-3 (0: switch open 1: switch closed)
	3	Relay SW1-4 (0: switch open 1: switch closed)
	4	Relay SW1-5 (0: switch open 1: switch closed)
	5	Relay SW1-6 (0: switch open 1: switch closed)
	6	(not used)
	7	(not used)

Table 3-4, Port B Register Functionality of the 1260-167 Module

Register Table		Port B
Module Version	Bit	Functionality Description
-167B only	0	Relay SW2-1 (0: switch open 1: switch closed)
	1	Relay SW2-2 (0: switch open 1: switch closed)
	2	Relay SW2-3 (0: switch open 1: switch closed)
	3	Relay SW2-4 (0: switch open 1: switch closed)
	4	Relay SW2-5 (0: switch open 1: switch closed)
	5	Relay SW2-6 (0: switch open 1: switch closed)
	6	(not used)
	7	(not used)

Table 3-5, EPROM Descriptor Functionality of the 1260-167 Module

Register Table		EPROM Descriptor Register
Module Version	Bit	Functionality Description
All	0	Each time this register is read, it advances a memory pointer to the next memory location in the on-board EPROM. To reset this pointer to the beginning, read the ID register. This resets the memory pointer. The descriptor register contains a long string of data, typically used by the Adapt-a-Switch carrier for configuration purposes. Additionally, this data contains the card identification string for the specific type of card (i.e. 1260-167A or 1260-167B). These identification strings are located at EPROM memory locations 0x23 through 0x34.
	1	
	2	
	3	
	4	
	5	
	6	
	7	

Writing to a port location is a straightforward process. Setting a bit high in a port register causes the corresponding relay channel to close.

It is especially important to realize that a single write operation controls eight separate control lines or output devices simultaneously. Therefore if only a single bit change is desired, the following process must be observed.

1. Read the register, inverting the bit pattern.
2. Mask the appropriate bit with an 'AND' operation and a byte mask with all undesired bits set to a '1' and the desired bit set to a '0' or '1' depending on whether the bit is to be set or cleared in the desired register.
3. Write the masked data back into the register.

As simple as this may seem, a number of products reported as faulty and sent back for repair are typically the result of inappropriate register accesses.

Because of the 1260-167 relay driver architecture, registers A and B will read back inverted from what was written to them.

The VISA I/O library may be used to control the module. The VISA function `viOut8()` is used to write a single 8-bit byte to a control register, while `viIn8()` is used to read a single 8-bit byte from the control register. The following code example shows the use of `viOut8()` to update the 1260-167 module.

1260-167 Example Code

```
#include <visa.h>

/* This example shows a 1260-01T at logical address 16 and a VXI/MXI */
/* interface */
#define RI1260_01_DESC      "VXI::16"

/* For a GPIB-VXI interface, and a logical address of 77 */
/* the descriptor would be: "GPIB-VXI::77" */

/* this example shows a 1260-167 with module address 7, port 1,
and write data of 0xAA */
#define MOD_ADDR_167  7
#define PORT_NUMBER   1
#define DATA_ITEM     0xAA

void example_operate_1260_167(void)
{
    ViUInt8 creg_val;
    ViBusAddress portA_addr, offset;
    ViSession hdl1260;    /* VISA handle to the 1260-01T */
    ViSession hdlRM;     /* VISA handle to the resource manager */
    ViStatus error;      /* VISA error code */

    /* open the resource manager */
    /* this must be done once in application program */
    error = viOpenDefaultRM (&hdlRM);

    if (error < 0) {
        /* error handling code goes here */
    }

    /* get a handle for the 1260-01T */
    error = viOpen (hdlRM, RI1260_01_DESC, VI_NULL,VI_NULL, &hdl1260);
    if (error < 0) {
        /* error handling code goes here */
    }
}
```

```
/* form the offset for control register 0 */
/* note that the base A24 Address for the 1260-01T */
/* is already accounted for by VISA calls viIn8() and */
/* viOut8() */

/* module address shifted 10 places = module address x 1024 */
portA_addr = (MOD_ADDR_167 << 10) + 1;
offset = portA_addr + (PORT_NUMBER << 1);

error = viOut8 (vi, VI_A24_SPACE, offset, DATA_ITEM);

if (error < 0)

    return( error );

/* close the VISA session */
error = viClose( hdl1260 );
if (error < 0) {
    /* error handling code goes here */
}
}
```

This page was left intentionally blank.

Chapter 4

PRODUCT SUPPORT

Product Support

EADS North America Defense Test and Services, Inc. has a complete Service and Parts Department. If you need technical assistance or should it be necessary to return your product for repair or calibration, call 1-800-722-3262. If parts are required to repair the product at your facility, call 1-949-859-8999 and ask for the Parts Department.

When sending your instrument in for repair, complete the form in the back of this manual.

For worldwide support and the office closest to your facility, refer to the website for the most complete information <http://www.eads-nadefense.com>.

Warranty

Use the original packing material when returning the 1260-167 to EADS North America Defense Test and Services, Inc. for calibration or servicing. The original shipping container and associated packaging material will provide the necessary protection for safe reshipment.

If the original packing material is unavailable, contact EADS North America Defense Test and Services, Inc. Customer Service at 1-800-722-3262 for information.

REPAIR AND CALIBRATION REQUEST FORM

To allow us to better understand your repair requests, we suggest you use the following outline when calling and include a copy with your instrument to be sent to the EADS North America Defense Test and Service, Inc. Repair Facility.

Model _____ Serial No. _____ Date _____

Company Name _____ Purchase Order # _____

Billing Address _____

City

State/Province

Zip/Postal Code

Country

Shipping Address _____

City

State/Province

Zip/Postal Code

Country

Technical Contact _____ Phone Number () _____

Purchasing Contact _____ Phone Number () _____

1. Describe, in detail, the problem and symptoms you are having. Please include all set up details, such as input/output levels, frequencies, waveform details, etc.

2. If problem is occurring when unit is in remote, please list the program strings used and the controller type.

3. Please give any additional information you feel would be beneficial in facilitating a faster repair time (i.e., modifications, etc.)

4. Is calibration data required? Yes No (please circle one)

Call before shipping Ship instruments to nearest support office.

Note: We do not accept
"collect" shipments.